

Water Hammer Solenoid Valve S1110 Series (G 3/4", G1")

NORMALLY CLOSED

2 WAY

PILOT OPERATED

$\Delta P=0,5$



GENERAL FEATURES

- New design
- TORK series S1110 (N.C.) diaphragm solenoid valves are 2/2 way and pilot operated.
- Suitable for non-aggressive liquids (water, light oil etc...) gaseous fluids (air, inert gases etc...)
- Minimum operating pressure differential 0,5 bar.
- Wide pressure range, flow rate and orifis options.
- Solenoid valves are used with filters.
- Solenoid valves can be mounted in any position without affecting its operation, coil to be used in a vertical position.
- No pressure difference is required.
- S1110 solenoid valves open quickly; their closing adjustment can be adjusted by rigging screw and they can remain open continuously by adjusting their rigging screw when it needs to stay open for a long time.

ELECTRICAL CHARACTERISTICS

Continuous Duty	: ED %100
Coil Insulation Class	: H (180°C)(IEC 85)
Coil Impregnation	: Polyester Fiber Glass
Ambient Temperature	: -20°C, +60°C
Protection Degree	: IP65 (ISO 60529) On request; IP68
Electric Plug Connection	: DIN 46340 3- Poles Connector (DIN143650)
Connector Specification	: ISO 4400 / EN 175301-803 Form A, Spade Plug (Cable Ø6-8 mm)
Electrical Safety	: IEC 335
Standard Voltages	: For AC 12V, 24V, 48V, 110V, 230V For DC 12V, 24V, 48V, 110V

On request other voltages;

Voltages Tolerance : AC -15%, +10% DC -5%, +10%

Frequency : 50 Hz (60 Hz...)

On request: connector with LED Specify coil voltage with order

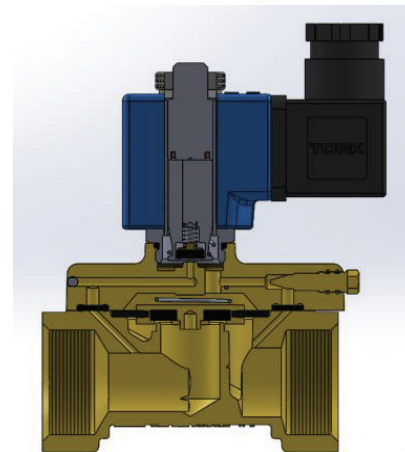

MATERIALS IN CONTACT WITH FLUID

Body	: Brass
Internal Parts	: Stainless Steel and Brass
Sealing	: NBR on request; VITON, EPDM
Shading Ring	: Copper
Seats, Core Tube, Springs	: Stainless Steel

OPTIONS

Female connection: BSP; (On request NPT)

- Manual use on request.
- On request CR-Ni coating.
- On request PTFE coating.
- On request Atex (exproof) coil.

TECHNICAL FEATURES

Max. Viscosity : 5°E (-37cST or mm²/s)

Response Time : Opening time : 400 ms to 1600 ms
Closing Time : 1000 ms to 2000 ms

SEALS FEATURES

NBR : -20°C...+80°C

EPDM : -30°C...+130°C

VITON : -20°C...+160°C

PTFE : -10°C...+160°C

RUBY : -10°C...+160°C

Coils	Nominal Values	Cold/ Hot	Inrush	Holding	Current (A)	Surface Temperature (°C)
C40012VDC18W	12VDC 18W	COLD	19,56	19,56	1,63	20
		HOT	14,52	14,52	1,21	106
C40024VDC18W	24VDC 18W	COLD	20,88	20,88	0,87	25
		HOT	14,64	14,64	0,61	116
C40110VDC18W	110VDC 18W	COLD	19,96	19,96	0,18	23
		HOT	13,56	13,56	0,123	115
C40012VAC15VA	12VAC 15VA	COLD	23,81	16,43	1,3	25
		HOT	-	15,86	1,262	79
C40024VAC15VA	24VAC 15VA	COLD	25,82	15,02	0,62	22
		HOT	-	13,91	0,57	81
C40110VAC15VA	110VAC 15VA	COLD	30,65	15,17	0,137	24
		HOT	-	13,96	0,126	80
C40230VAC15VA	230VAC 15VA	HOT	31,4	15,64	0,068	25
		HOT	-	14,41	0,063	80
C40230VAC24VA	230VAC 24VA	COLD	45,1	23,92	0,0154	23
		HOT	-	21,62	0,0154	100

Solenoid Valve Symbol	Valve Type/ Order No	Connection Size	Orifis Size	Pressure min/max		Kv	Fluid Temperature min/max		Seal	Weight		
				Bar	Bar		l/min	°C				
	S1110	G	mm	Bar	Bar	l/min	°C	°C	NBR	Option	kg	
	S1110.04	3/4"	17	0,5	16	90	-20	+80	✓	✓	✓	0,9
	S1110.05	1"	17	0,5	16	90	-20	+80	✓	✓	✓	1

STANDARDS

- Standard tube connection G (BSP) (ISO 228-1) and other tube connections (NPT (ANSI 1.20.3)) are available on request.
- TORK solenoid valves 97/23/EC, are available for pressure equipment directive (PED) and 2006/95/ECC low voltage directive (LVD).

Not: Please look catalogues for more details