

tork

valve & automation

PNEUMATIC ACTUATORS USER MANUEL



PLEASE READ THE INSTRUCTIONS BEFORE USE

2026



CONTENTS

1. GENERAL DESCRIPTION OF THE EQUIPMENT.....	3
a. Intended Use Of The Equipment.....	3
b. Product Coding System.....	4
c. Exploded Drawings and Part Lists.....	5
d. General Features.....	9
e. Warning Signs and Labeling.....	14
2. OPERATION OF THE EQUIPMENT.....	15
a. Operation of Double Acting Actuators.....	15
b. Operation of Spring Return Actuators.....	16
c. Operation of 3 Position Actuator.....	17
3. INSTALLATION OF THE EQUIPMENT.....	18
a. Mounting the Actuator to Valve Assembly.....	18
b. Stroke Adjustment.....	20
c. Mounting the Namur Solenoid to Actuator Assembly.....	21
d. Mounting the Switch Box to Actuator Assembly.....	22
e. Mounting the Position Indicator to Actuator Assembly.....	22
f. Ground Connection.....	23
g. BActuator Supply Condition.....	23
4. SAFETY MANUAL	24
5. FUNCTIONAL SAFETY RELEVANT SPECIFICATIONS.....	25
6. OPERATION AND MAINTENANCE.....	26
WARRANTY CONDITION.....	27
EXCLUSIONS OF WARRANTY (USAGE DEFECTS).....	27
WARRANTY CERTIFICATE.....	28
QUALITY CERTIFICATES.....	29

1. GENERAL DESCRIPTION OF THE EQUIPMENT

a. Intended Use Of The Equipment

TORK Pneumatic Actuators are powerful, reliable and compact double rack pinion units for use with ball, butterfly and plug valves and any device requiring accurate fast or slow or proportional 90° turn motion. TORK Pneumatic Actuators are manufactured 7 different sizes both double acting and single acting spring return type. Besides standard manufacturing program, optionally pneumatic actuators can be manufactured with \pm %10 stroke adjustable, 180° turn and 3- position types (open, half open, closed).

Any power operated device used to operate a valve. The device is designed to operate using motive energy which may be electrical, pneumatic, hydraulic, etc., or a combination of these. Movement is limited by travel, torque or thrust Pneumatic Actuator is an automatic control device which open and close the rotating valves with the help of compressed air.

Pneumatic Actuators can be separated into two general groups: 1- Spring Return Actuators. 2- Double Acting Actuators. In Spring Return Actuators (Fig 1) the opening operation is done by pressurized air and the closing is done by springs. In Double Acting Actuators (Fig 2) opening and closing operations both are done by pressurized air.

Pneumatic actuators are using in different piping systems to open or close the valves. This equipment also related to the fluids, flow in the pipes can be used in explosive regions(ZONE I).



Fig 1. Spring Return Actuators



Fig 2. Double Acting Actuators

b. Product Coding System

RA040.SR.09.036.000

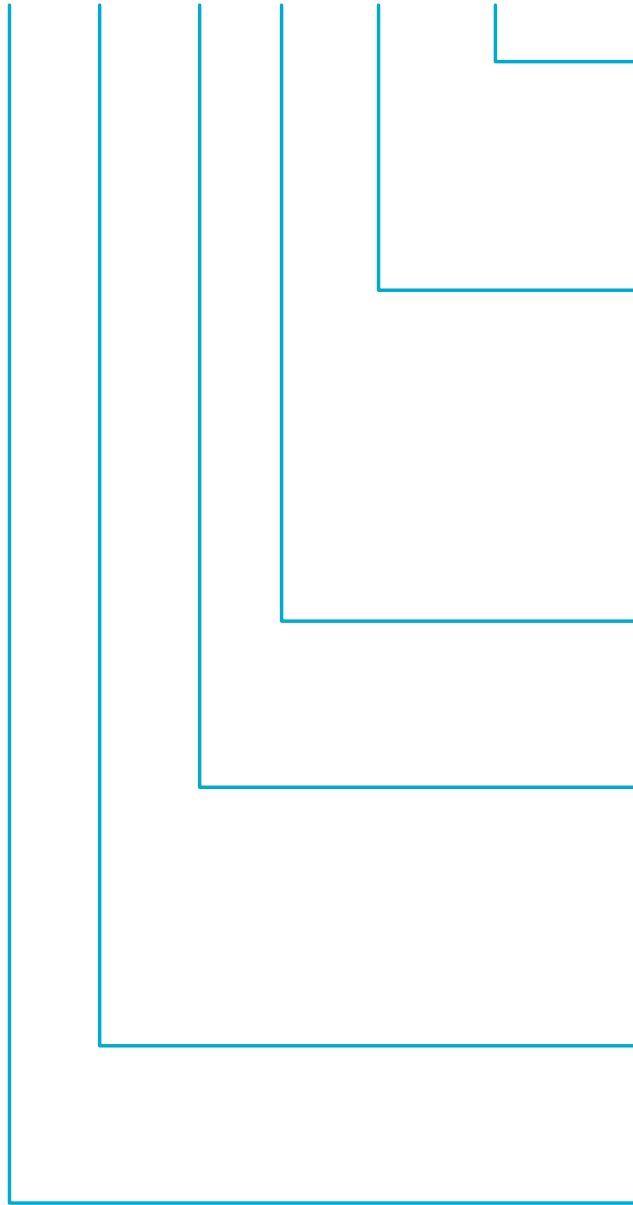

Outer Flange Sizes

Single Flange	000
Ø 50	050
Ø 70	070
Ø 102	102
Ø 140	140

Inner Flange Sizes

Ø 36	036
Ø 42	042
Ø 50	050
Ø 70	070
Ø 102	102
Ø 125	125
Ø 140	140
Ø 165	165

Square Head Dimensions

09	17	36
11	22	
14	27	

TYPE

SR	Single Acting
DA	Double Acting
3 P	3 Position 90° Turn
8 D	180° Turn
2 D	120° Turn
8P	3 Position 180° Turn

Body Sizes

032	080	143	270
040	100	160	350
060	120	200	

Features

RA	Standard
RX	Exproof
RAM	Arctic Actuator (-50 °C)
RXM	Cold Medium - Exproof
RAH	Heavy Duty Series
RASY	Scotchyoce Actuator
RASYM	Scotchyoce Arctic Actuator

c. Exploded Drawings and Part Lists

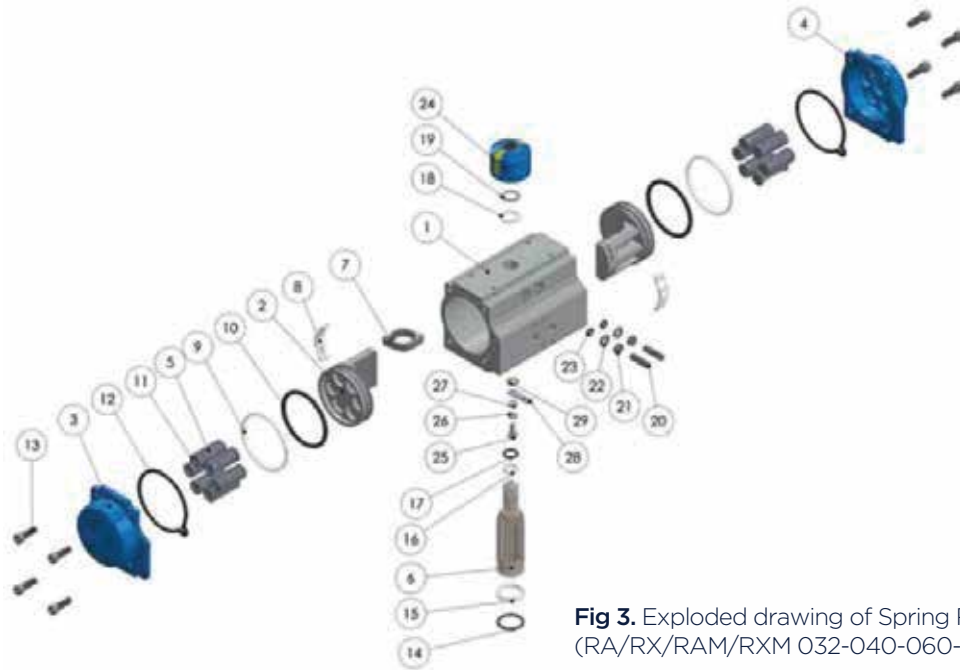

Fig 3. Exploded drawing of Spring Return Actuators (RA/RX/RAM/RXM 032-040-060-080-100-200 SR)

29	SERRATED LOCK WASHER DIN 6798 M5	STAINLESS STEEL	NOS	1
28	GROUND CONNECTOR	BRASS	NOS	1
27	WASHER DIN 125 M5	STAINLESS STEEL	NOS	1
26	SPRING WASHER DIN 6799 M5	STAINLESS STEEL	NOS	1
25	BOLT DIN 7985 M5X16	STAINLESS STEEL	NOS	1
24	INDICATOR	ABS	NOS	1
23	O-RING (STOP SET SCREW)	NITRILE (NBR 70)	NOS	2
22	STOP SET SCREW WASHER DIN 125 M6	STAINLESS STEEL	NOS	2
21	STOP NUT DIN 934 M6	STAINLESS STEEL	NOS	2
20	STOP SET SCREW DIN 916 M6X25	STAINLESS STEEL	NOS	2
19	SPRING CLIP (PINION) DIN 471/15	STEEL ALLOY	NOS	1
18	THRUST BEARING (PINION)	POLYPHTALAMIDE	NOS	1
17	O-RING (PINION TOP)	NITRILE (NBR 70)	NOS	1
16	BEARING (PINION TOP)	POLYPHTALAMIDE	NOS	1
15	BEARING (PINION BOTTOM)	POLYPHTALAMIDE	NOS	1
14	O-RING (PINION BOTTOM)	NITRILE (NBR 70)	NOS	1
13	COVER BOLT DIN 912 M5X16	STAINLESS STEEL	NOS	8
12	O-RING (COVER)	NITRILE (NBR 70)	NOS	2
11	SPRING HOLDER	POLYPROPYLENE + GF	NOS	min.5 / max.12
10	O-RING (PISTON)	NITRILE (NBR 70)	NOS	2
9	BEARING (PISTON SLIDING)	POLYPHTALAMIDE	NOS	2
8	BEARING (PISTON BACK)	POLYPHTALAMIDE	NOS	2
7	CAM (STOP ARRANGEMENT)	STAINLESS STEEL	NOS	1
6	PINION	STEEL ALLOY	NOS	1
5	SPRING	HIGH ALLOY SPRING STEEL	NOS	min.5 / max.12
4	COVER RIGHT	DIE CAST ALUMINIUM	NOS	1
3	COVER LEFT	DIE CAST ALUMINIUM	NOS	1
2	PISTON	DIE CAST ALUMINIUM	NOS	2
1	BODY	EXTRUDED ALUMINIUM ALLOY	NOS	1
No	Part Name	Material	Unit	Quantity

Tab 1. Part list of Spring Return Actuators (RA/RX/RAM/RXM 032-040-060-080-100-200 SR)

c. Exploded Drawings and Part Lists

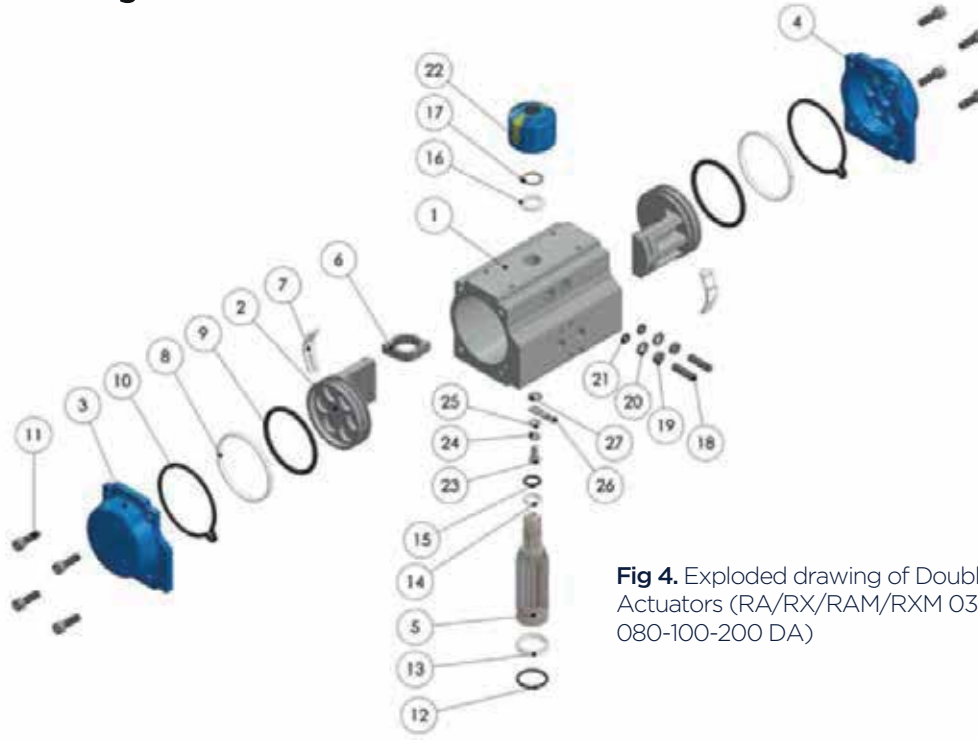
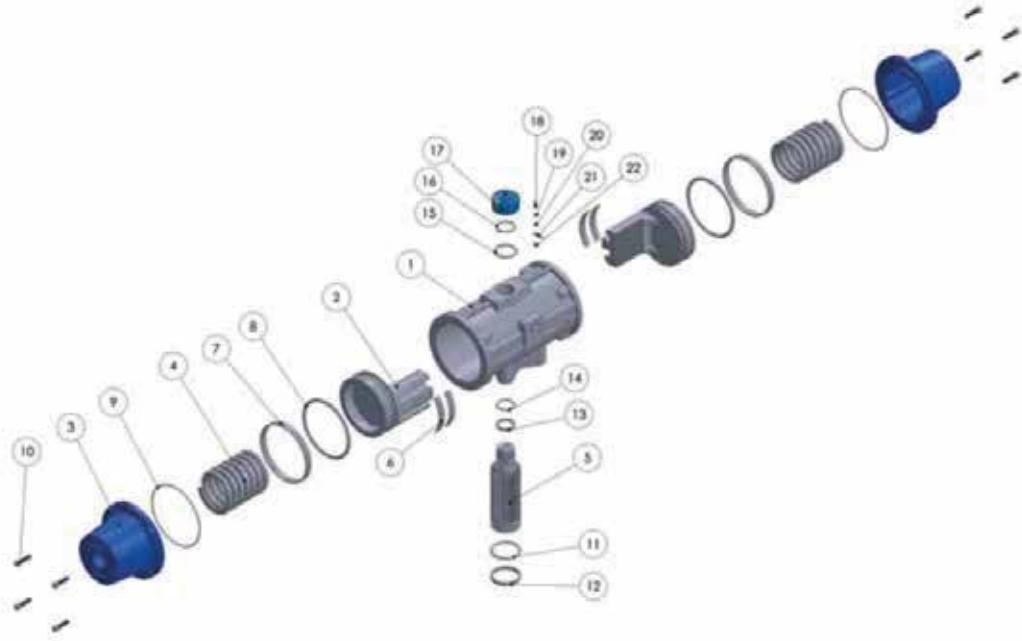

Fig 4. Exploded drawing of Double Acting Actuators (RA/RX/RAM/RXM 032-040-060-080-100-200 DA)

27	SERRATED LOCK WASHER DIN 6798 M5	STAINLESS STEEL	NOS	1
26	GROUND CONNECTOR	BRASS	NOS	1
25	WASHER DIN 125 M5	STAINLESS STEEL	NOS	1
24	SPRING WASHER DIN 6799 M5	STAINLESS STEEL	NOS	1
23	BOLT DIN 7985 M5X16	STAINLESS STEEL	NOS	1
22	INDICATOR	ABS	NOS	1
21	O-RING (STOP SET SCREW)	NITRILE (NBR 70)	NOS	2
20	STOP SET SCREW WASHER DIN 125 M6	STAINLESS STEEL	NOS	2
19	STOP NUT DIN 934 M6	STAINLESS STEEL	NOS	2
18	STOP SET SCREW	STAINLESS STEEL	NOS	2
17	SPRING CLIP (PINION) DIN 471/15	STEEL ALLOY	NOS	1
16	THRUST BEARING (PINION)	POLYPHTALAMIDE	NOS	1
15	O-RING (PINION TOP)	NITRILE (NBR 70)	NOS	1
14	BEARING (PINION TOP)	POLYPHTALAMIDE	NOS	1
13	BEARING (PINION BOTTOM)	POLYPHTALAMIDE	NOS	1
12	O-RING (PINION BOTTOM)	NITRILE (NBR 70)	NOS	1
11	COVER BOLT DIN 912 M5X16	STAINLESS STEEL	NOS	8
10	O-RİNG (COVER)	NITRILE (NBR 70)	NOS	2
9	O-RING (PISTON)	NITRILE (NBR 70)	NOS	2
8	BEARING (PISTON SLIDING)	POLYPHTALAMIDE	NOS	2
7	BEARING (PISTON BACK)	POLYPHTALAMIDE	NOS	2
6	CAM (STOP ARRANGEMENT)	STAINLESS STEEL	NOS	1
5	PINION	STEEL ALLOY	NOS	1
4	COVER RIGHT	DIE CAST ALUMINIUM	NOS	1
3	COVER LEFT	DIE CAST ALUMINIUM	NOS	1
2	PISTON	DIE CAST ALUMINIUM	NOS	2
1	BODY	EXTRUDED ALUMINIUM ALLOY	NOS	1
No	Part Name	Material	Unit	Quantity

Tablo 2. Çift Etkili Aktüatör parça listesi (RA/RX/RAM/RXM 032-040-060-080-100-200 DA)

c. Exploded Drawings and Part Lists



Şekil 5. Exploded drawing of Spring Return Actuators (RA/RX/RAM/RXM 143-160-200-270-350 SR)

22	SERRATED LOCK WASHER DIN 6798 M5	STAINLESS STEEL	NOS	1
21	GRAUND CONNECTOR	BRASS	NOS	1
20	WASHER DIN 125 M5	STAINLESS STEEL	NOS	1
19	SPRING WASHER DIN 6799 M5	STAINLESS STEEL	NOS	1
18	BOLT DIN 7985 M5X16	STAINLESS STEEL	NOS	1
17	INDICATOR	ABS	NOS	1
16	SPRING CLIP (PINION) DIN 471/38	STEEL ALLOY	NOS	1
15	THRUST BEARING (PINION)	POLYPHTALAMIDE	NOS	1
14	O-RING (PINION TOP)	NITRILE	NOS	1
13	BEARING (PINION TOP)	POLYPHTALAMIDE	NOS	1
12	BEARING (PINION BOTTOM)	POLYPHTALAMIDE	NOS	1
11	O-RING (PINION BOTTOM)	NITRILE	NOS	1
10	COVER BOLT DIN 912 M8X35	PASLANMAZ ÇELİK	NOS	8
9	O-RING (COVER)	NITRILE	NOS	2
8	O-RING (PISTON)	NITRILE	NOS	2
7	BEARING (PISTON SLIDING)	POLYPHTALAMIDE	NOS	2
6	BEARING (PISTON BACK)	POLYPHTALAMIDE	NOS	2
5	PINION	STEEL ALLOY	NOS	1
4	SPRING	HIGH ALLOY SPRING STEEL	NOS	2
3	COVER	CASTING ALUMINIUM	NOS	2
2	PISTON	CASTING ALUMINIUM	NOS	2
1	BODY	CASTING ALUMINIUM ALLOY	NOS	1
No	Part Name	Material	Unit	Quantity

Tab 3. Part list of Spring Return Actuators (RA/RX/RAM/RXM 143-160-200-270-350 SR)

c. Exploded Drawings and Part Lists

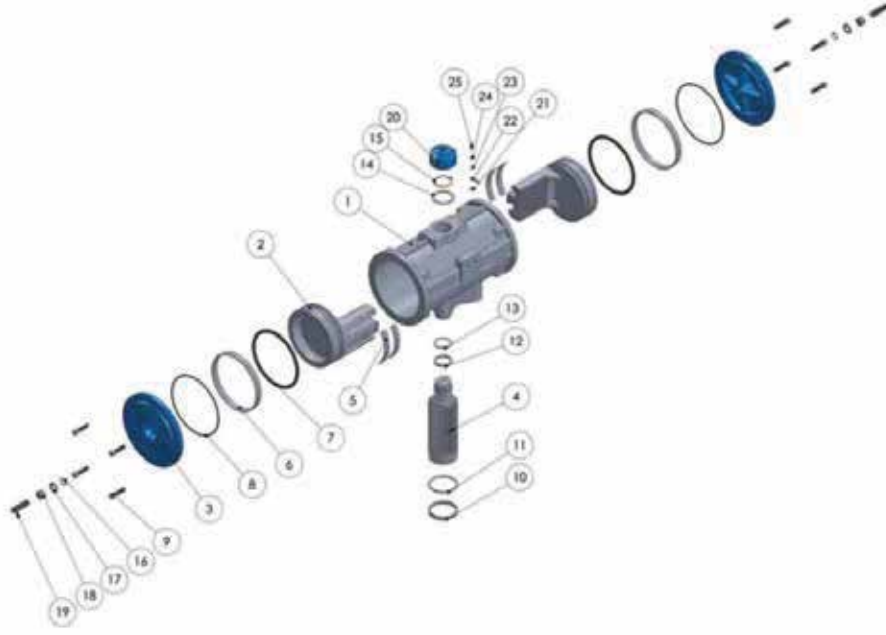

Şekil 6. Exploded drawing of Double Acting Actuators (RA/RX/RAM/RXM 143-160-200-270-350 DA)

25	BOLT	STAINLESS STEEL	NOS	1
24	SPRING WASHER	STAINLESS STEEL	NOS	1
23	WASHER	STAINLESS STEEL	NOS	1
22	GROUND CONNECTOR	BRASS	NOS	1
21	SERRATED LOCK WASHER	STAINLESS STEEL	NOS	1
20	INDICATOR	ABS	NOS	1
19	O-RING (STOP SET SCREW)	NITRILE	NOS	2
18	STOP SET SCREW WASHER	STAINLESS STEEL	NOS	2
17	STOP NUT	STAINLESS STEEL	NOS	2
16	STOP SET SCREW	STAINLESS STEEL	NOS	2
15	SPRING CLIP (PINION)	STEEL ALLOY	NOS	1
14	THRUST BEARING (PINION)	POLYPHTALAMIDE	NOS	1
13	O-RING (PINION TOP)	NITRILE	NOS	1
12	BEARING (PINION TOP)	POLYPHTALAMIDE	NOS	1
11	BEARING (PINION BOTTOM)	POLYPHTALAMIDE	NOS	1
10	O-RING (PINION BOTTOM)	NITRILE	NOS	1
9	COVER BOLT	STAINLESS STEEL	NOS	8
8	O-RING (COVER)	NITRILE	NOS	2
7	O-RING (PISTON)	NITRILE	NOS	2
6	BEARING (PISTON SLIDING)	POLYPHTALAMIDE	NOS	2
5	BEARING (PISTON BACK)	POLYPHTALAMIDE	NOS	2
4	PINION	STEEL ALLOY	NOS	1
3	COVER	DIE CAST ALUMINIUM	NOS	2
2	PISTON	DIE CAST ALUMINIUM	NOS	2
1	BODY	EXTRUDED ALUMINIUM ALLOY	NOS	1
No	Part Name	Material	Unit	Quantity

Tablo 4. Part list of Double Acting Actuators (RA/RX/RAM/RXM 143-160-200-270-350 DA)

d. General Features

- High performance
- High cycle life (1.000.000 operation)
- High torque value
- Standard position indicator
- For quarter turn valve automation (9Nm - 5162Nm)
- One compact design for double and single acting models
- Dual piston rack and pinion
- According to international standards (NAMUR, ISO5211)
- Body: Extruded aluminium
- Piston & Caps: Die cast aluminium
- 90° turn, two external travel stop adjustment 35%
- 100% adjustable travel stop (on request)

Pressure : Double acting: 2.5 bar 8 bar

Single acting : 4 bar 8 bar

Temperature : Standard -20 °C 80 °C

On request -20 °C 150 °C, -30 °C 80 °C

- TORK Pneumatic actuators have been manufactured since 198
- **Lubrication :** All moving parts are factory lubricated 6
- On request; exproof model (II 2G EEx c IIB T4)



Anodized Body
(Standard)



Epoxy Coated
Body



Nickel Coated
Body



PTFE Coated
Body



100% Adjustable
on request

Atex (2014 / 34 / EU)

Atex electrical actuators are the products that are used in potentially explosive or hazardous environments. There are important requirements to be aware of when using these products. In the event that one or more of these conditions are not met, the user is liable. Atex products;

- Must be used with Atex certified appropriate cable.
- The product cover should never be opened when actuator is in energy.
- Grounding must be done.
- Use for grounding min 4 mm² cable produced in HD21 or HD22 standards .
- It is suitable for use in ZONE 1 and ZONE 2 environments (II 2G Ex h IIC T5 Gb, II 2D Ex h IIIC T135°C Db).

e. Design Features of TORK RA Serie Actuators

- 1) Actuator Body Aluminium extruded and honed surface body. Internal and external parts corrosion protected
- 2) Indicator It is standard on all actuators, it shows visual position of valve
- 3) Cover Provide max. resistance against corrosive elements, same cap design for double and single types actuators
- 4) Travel Adjustment Permits adjustment of $\pm 5\%$ in both directions
- 5) Springs Springs provide high performance in safe emergency shutdown operation.
Cartridge design & corrosion resistant
- 6) Bearing & Piston Guides High cycle life, wide operation temperature range, lubricating provide high performance
- 7) Nuts & Bolts Stainless steel body. Provide long term corrosion resistance.
- 8) Piston Rack and Pinion Provides wear resistance and protect against corrosion.
Die cast pistons anodized aluminium fitted with high quality seals and guides.
- 9) Connections
 - Solenoid valves, switch box, positioners:
Namur VDI/VDE 3845
 - Bottom valve connection: ISO5211, DIN3337 standard



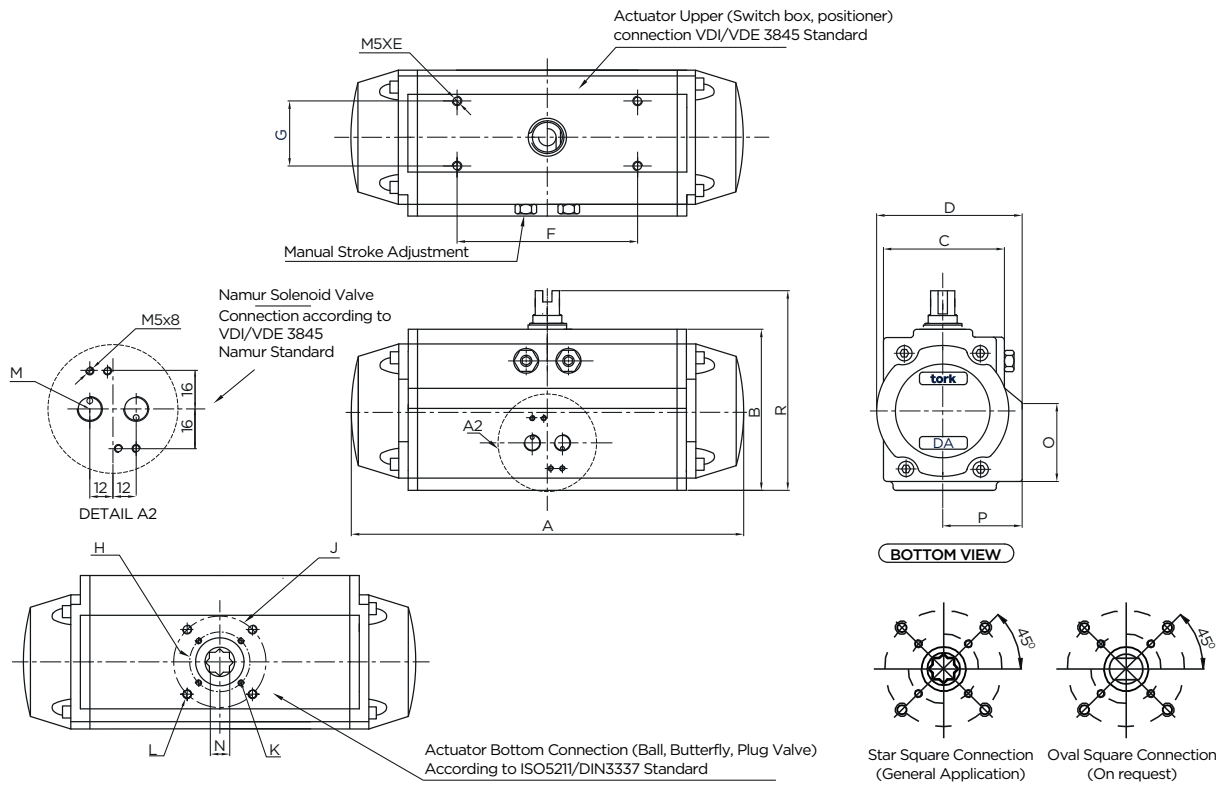
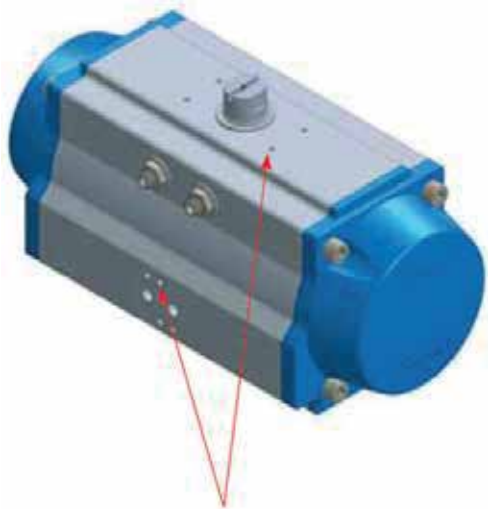
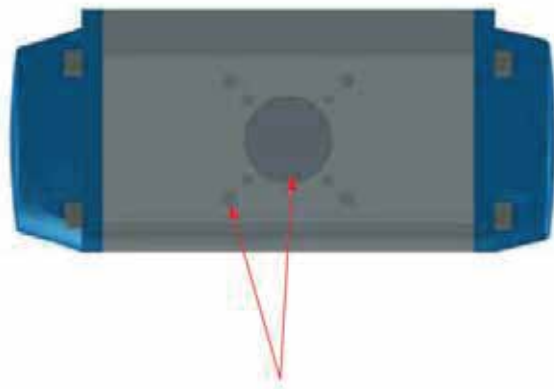

Fig 8. General Dimensions of TORK Actuators



VDI/VDE 3845 (NAMUR)



ISO 5211

DIMENSION (mm)																		
ACTUATOR MODEL	A	B	C	D	E	F	G	H	J	K	L	M	N	O	P	R	ISO FLANGE FOR H	ISO FLANGE FOR J
RA/RX/RAM/RXM 32 DA	98	47	45	-	8.0	50	25	36	-	M5	-	1/8"	9	-	-	67	F03	-
RA/RX/RAM/RXM 40 DA/SR	137.2	70	52.0	70.6	8.0	80.0	30.0	36/42/50	-	M5	M6	1/8"	9/11	45.0	39.7	90	F03/F04	F05
RA/RX/RAM/RXM 52 DA/SR	172.6	85	62.0	82.7	8.0	80.0	30.0	42/50	70.0	M5/M6	M8	1/8"	9/11/14	47.0	47.0	105	F04/F05	F07
RA/RX/RAM/RXM 60 DA/SR	172.6	85	62.0	82.7	8.0	80.0	30.0	42/50	70.0	M5/M6	M8	1/8"	9/11/14	47.0	47.0	105	F04/F05	F07
RA/RX/RAM/RXM 75 DA/SR	242.0	117	91.8	109.2	8.0	80.0	30.0	50	70.0	M6	M8	1/8"	11/14/17	54.8	58.3	137	F05	F07
RA/RX/RAM/RXM 80 DA/SR	242.0	117	91.8	109.2	8.0	80.0	30.0	50	70.0	M6	M8	1/8"	11/14/17	54.8	58.3	137	F05	F07
RA/RX/RAM/RXM 100 DA/SR	282.0	130	95.0	121.0	8.0	80.0	30.0	70	102.0	M8	M10	1/4"	14/17/22	61.0	65.0	150	F07	F10
RA/RX/RAM/RXM 120 DA/SR	360.0	158	116.2	150.0	8.0	80.0	30.0	70	102.0	M8	M10	1/4"	17/22	82.0	87.2	178	F07	F10
RA/RX/RAM/RXM 143 DA/SR	408.5	180	140	169	8.0	80.0	30.0	102	140	M10	M16	1/4"	22/27	68	89	200	F10	F14
RA/RX/RAM/RXM 160 DA	454	200	160	190.5	8.0	80/130	30.0	102	140	M10/M16	M16	1/4"	22/27	61	101	219.5	F10	F14
RA/RX/RAM/RXM 200 DA	458	270	242	242	8.0	80.0	30.0	-	140/165	-	M20	1/4"	36	121	121	290	-	F14/F16
RA/RX/RAM/RXM 270 DA	540	354	-	330	8	130	30	-	165	-	M20	1/4"	46/55	-	-	384	-	F16
RA/RX/RAM/RXM 350 DA	586.3	440	-	440	8	130	30	-	165	-	M20	1/4"	46	-	-	470	-	F16
RA/RX/RAM/RXM 160 SR	558	215	202	202	8.0	80.0	30.0	102	140	M10	M16	1/4"	22/27	101	101	235	F10	F14
RA/RX/RAM/RXM 200 SR	680	270	242	242	8.0	80.0	30.0	-	140/165	M16	M20	1/4"	36	121	121	290	-	F14/F16
RA/RX/RAM/RXM 270 SR	775.5	354	-	330	8	130	30	-	165	-	M20	1/4"	46/55	-	-	384	-	F16
RA/RX/RAM/RXM 350 SR	866.5	440	-	440	8	130	30	-	165	-	M20	1/4"	46	-	-	470	-	F16

*F04 flange circle can be opened in a single size.

DIMENSION (mm)																		
ACTUATOR MODELS	A	B	C	D	E	F	G	H	J	K	L	M	N	O	P	R	ISO FLANGE FOR H	ISO FLANGE FOR J
RA/RX/RAM/RXM 40.2D	143.7	70	52	70.6	8	80	30	36/42*	50	M5	M6	1/8"	9/11	45	40	90	F03/F04	F05
RA/RX/RAM/RXM 60.2D	197.6	85.2	62	82.7	8	80	30	42/50	70	M5/M6	M8	1/8"	9/11/14	47	47	105	F04/F05	F07
RA/RX/RAM/RXM 80.2D	275	117	91.8	109	8	80	30	50	70	M6	M8	1/8"	11/14/17	55	58	137	F05	F07
RA/RX/RAM/RXM 100.2D	329	130	95	121	8	80	30	70	102	M8	M10	1/4"	14/17/22	61	65	160	F07	F10
RA/RX/RAM/RXM 120.2D	400	160	116.2	150	8	80	30	70	102	M8	M10	1/4"	17/22	82	87.2	190	F07	F10

*F04 flange circle can be opened in a single size

DIMENSION (mm)																		
ACTUATOR MODELS	A	B	C	D	E	F	G	H	J	K	L	M	N	O	P	R	ISO FLANGE FOR H	ISO FLANGE FOR J
RA/RX/RAM/RXM 40.8D	178.2	70	52	70.6	8	80	30	36/42*	50	M5	M6	1/8"	9/11	45	40	90	F03/F04	F05
RA/RX/RAM/RXM 60.8D	241.6	85.2	62	82.7	8	80	30	42/50	70	M5/M6	M8	1/8"	9/11/14	47	47	105	F04/F05	F07
RA/RX/RAM/RXM 80.8D	333	117	91.8	109	8	80	30	50	70	M6	M8	1/8"	11/14/17	55	58	137	F05	F07
RA/RX/RAM/RXM 100.8D	402	130	95	121	8	80	30	70	102	M8	M10	1/4"	14/17/22	61	65	160	F07	F10
RA/RX/RAM/RXM 120.8D	481	160	116.2	150	8	80	30	70	102	M8	M10	1/4"	17/22	82	87.2	190	F07	F10

ACTUATOR MODEL	OPEN VOLUME OPENING (L)	AIR VOLUME CLOSING (L)	OPENING TIME (sec)	CLOSING TIME (sec)	APPROXIMATE WEIGHT (kg)
RA/RX/RAM/RXM 32 DA	DA	0.03	0.02	0.1	0.4
RA/RX/RAM/RXM 40 DA/SR	DA	0.09	0.16	0.22	0.85
	SR			0.26	1.02
RA/RX/RAM/RXM 52 DA/SR	DA	0.17	0.28	0.27	1.70
	SR			0.33	1.80
RA/RX/RAM/RXM 60 DA/SR	DA	0.17	0.28	0.27	1.70
	SR			0.33	1.80
RA/RX/RAM/RXM 75 DA/SR	DA	0.50	0.79	0.39	3.80
	SR			0.48	4.40
RA/RX/RAM/RXM 80 DA/SR	DA	0.50	0.79	0.39	3.80
	SR			0.48	4.40
RA/RX/RAM/RXM 100 DA/SR	DA	0.73	1.15	0.52	4.90
	SR			0.63	6.10
RA/RX/RAM/RXM 120 DA/SR	DA	1.61	2.45	0.95	9.60
	SR			1.15	11.40
RA/RX/RAM/RXM 143 DA/SR	DA	2.62	2.94	1.2	17.8
	SR			2	20.6
RA/RX/RAM/RXM 160 DA	DA	3.25	2.56	2.60	22.4
RA/RX/RAM/RXM 200 DA	DA	6.41	5.50	3.40	33.40
RA/RX/RAM/RXM 270 DA	DA	13.75	10.45	4.3	65
RA/RX/RAM/RXM 350 DA	DA	25	19.40	5.20	125.00
RA/RX/RAM/RXM 160 SR	SR	3.25	0	3.80	26.80
RA/RX/RAM/RXM 200 SR	SR	6.41	0	4.80	45.90
RA/RX/RAM/RXM 270 SR	SR	13.75	0	5.3	68
RA/RX/RAM/RXM 350 SR	SR	25	0	6.20	155

Tablo 9. Special Dimensions of TORK Actuators

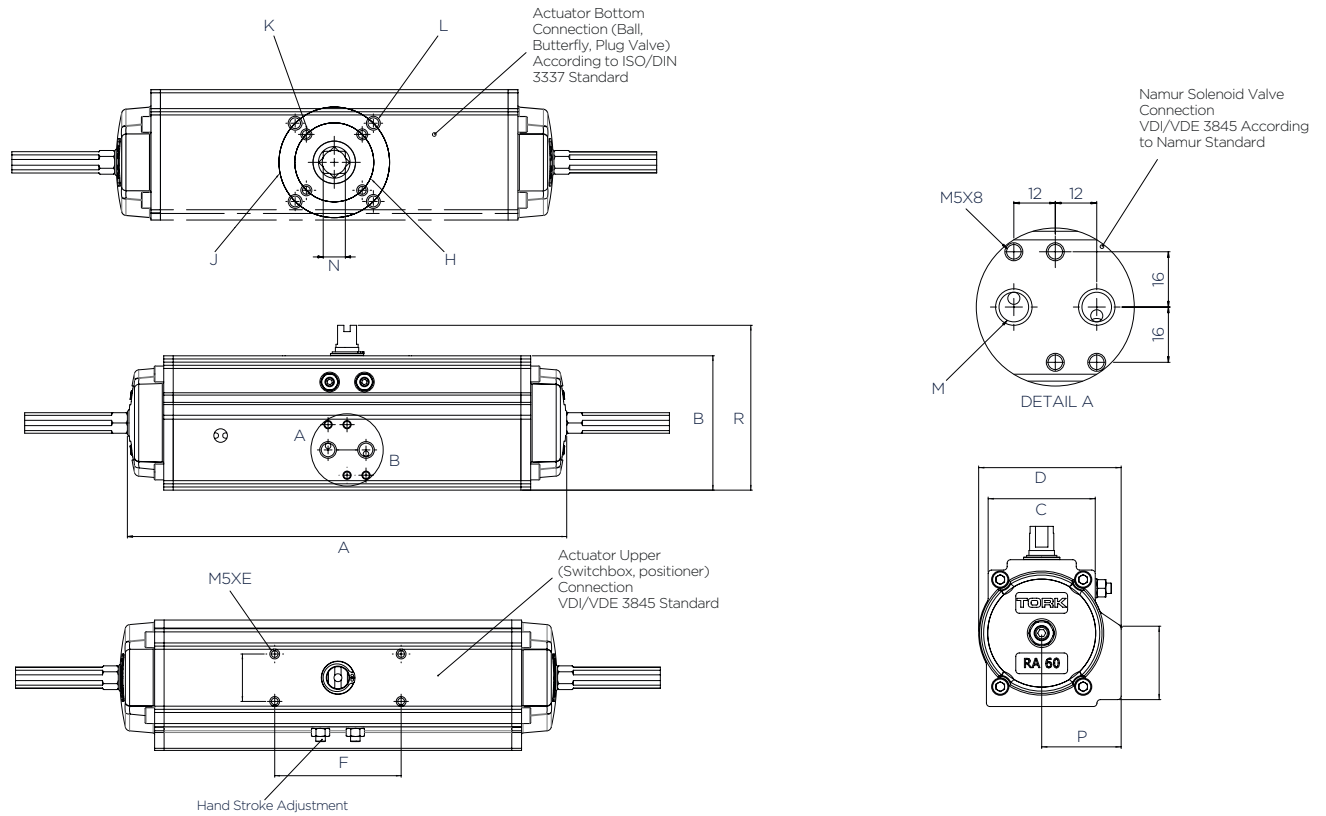

Fig 9. General Dimensions of 3 Position Actuators

TYPE ORDER NO	P: 6 bar Torque	DIMENSIONS (mm)																	
		RA	NM	A	B	C	D	E	F	G	H	J	K	L	M	N	O	P	R
RA/RX/RAM/RXM 40.P	15,8	143,7	70	52	70,6	8	80	30	36/42*	50	M5	M6	1/8"	9/11	45	40	90	F03/F04/F05	
RA/RX/RAM/RXM 60.P	39	197,6	85,2	62	82,7	8	80	30	42/50	70	M5/M6	M8	1/8"	9/11/14	47	47	105	F04/F05/F07	
RA/RX/RAM/RXM 80.P	94,6	275	117	91,8	109	8	80	30	50	70	M6	M8	1/8"	11/14/17	55	58	137	F05/F07	
RA/RX/RAM/RXM 100.P	168,7	329	130	95	121	8	80	30	70	102	M8	M10	1/4"	14/17/22	61	65	160	F07	
RA/RX/RAM/RXM 120.P	318,6	400	160	116,2	150	8	80	30	70	102	M8	M10	1/4"	17/22	82	87,2	190	F07	

*F04 flange circle can be opened in a single size.

Tab 12. General Dimensions of 3 Position Actuators

TYPE ORDER NO	P: 6 bar Torque	DIMENSION (mm)																	
		RA	Nm	A	B	C	D	E	F	G	H	J	K	L	M	N	O	P	R
RA/RX/RAM/RXM 40.8P	15,8	263	70	52	70,6	8	80	30	36/42*	50	M5	M6	1/8"	9/11	45	40	90	F03/F04/F05	
RA/RX/RAM/RXM 60.8P	39	347	85,2	62	82,7	8	80	30	42/50	70	M5/M6	M8	1/8"	9/11/14	47	47	105	F04/F05/F07	
RA/RX/RAM/RXM 80.8P	94,6	458,5	116,9	91,8	109,2	8	80	30	50	70	M6	M8	1/8"	11/14/17	54,8	58	136,9	F05/F07	
RA/RX/RAM/RXM 100.8P	168	550	130	95	121	8	80	30	70	102	M8	M10	1/4"	14/17/22	61	65	160	F07/F10	
RA/RX/RAM/RXM 120.8P	318	585	160	116,2	150	8	80	30	70	102	M8	M10	1/4"	17/22	82	87,2	190	F07/F10	

*F04 flange circle can be opened in a single size.

Tab 13. General Dimensions of 3 Position 180° Actuators

e. Warning Signs and Labeling



tork valve & automation

IECEx Ex n IIC T5 Gb
IECEx Ex n IIC T50°C Gb
Only For Air and Steam

SIL3 IEC61508
IEC61508

CE 2354

SMS Sanayi Malzemeleri Üretim ve Satış A.Ş. **Pneumatic Actuator**

Model: Config:

Type:

Serial No:

Operating Pressure:

Ambient Temperature:

Output Torque Value At 6 Bar:

Rotating Angle:

Production Date:

www.smstork.com

Made in Türkiye

- Pneumatic connections should be disconnected before any intervention.
- Refer to the instruction manual before any intervention.
- As pneumatic actuator can be used efficiently after 500.000 unpacking and packing, oring kits of product should be replaced.

2. OPERATION OF THE EQUIPMENT

a. Operation of Double Acting Actuators

Inline position



Port A: Pressurized to open the valve. Actuator rotates CCW for opening.
Port B: Pressurized for close the valve. Actuator rotates CW for closing.

Across position



Port A: Pressurized to open the valve. Actuator rotates CCW for opening.
Port B: Pressurized for close the valve. Actuator rotates CW for closing.

b. Operation of Spring Return Actuators

Inline position

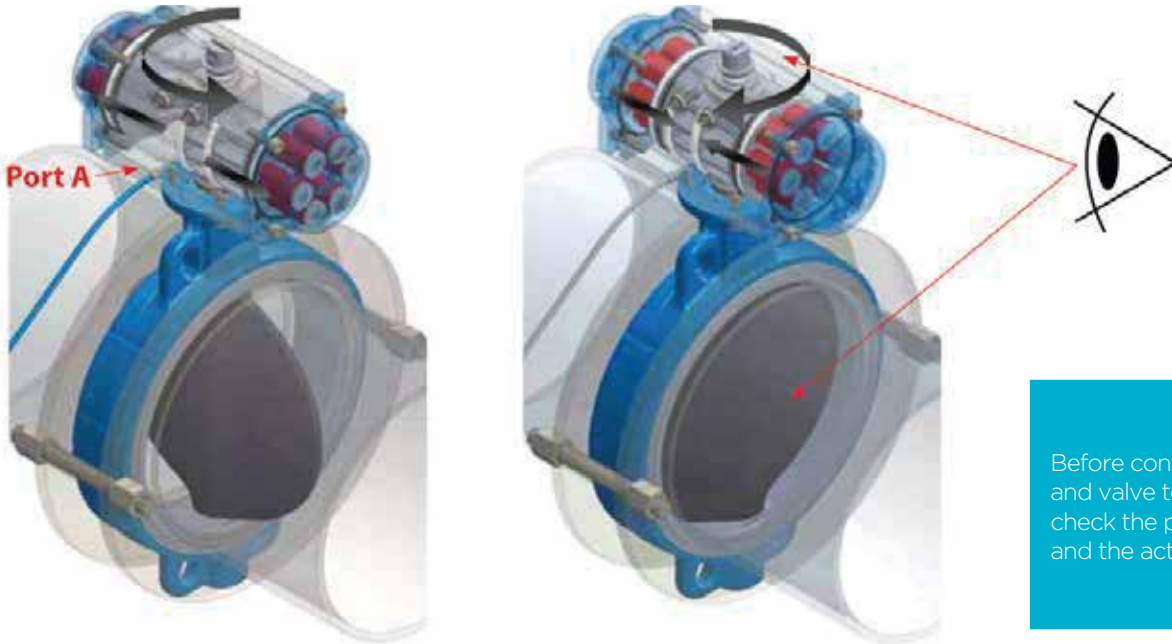

Before connect the actuator and valve to the piping system, check the position of the valve and the actuator pinion

Port A: Pressurized to open the valve. Actuator rotates CCW for opening.
 Port A: Non-Pressurized and springs made their jobs for closing the valve. Actuator rotates CW for closing.

Across position

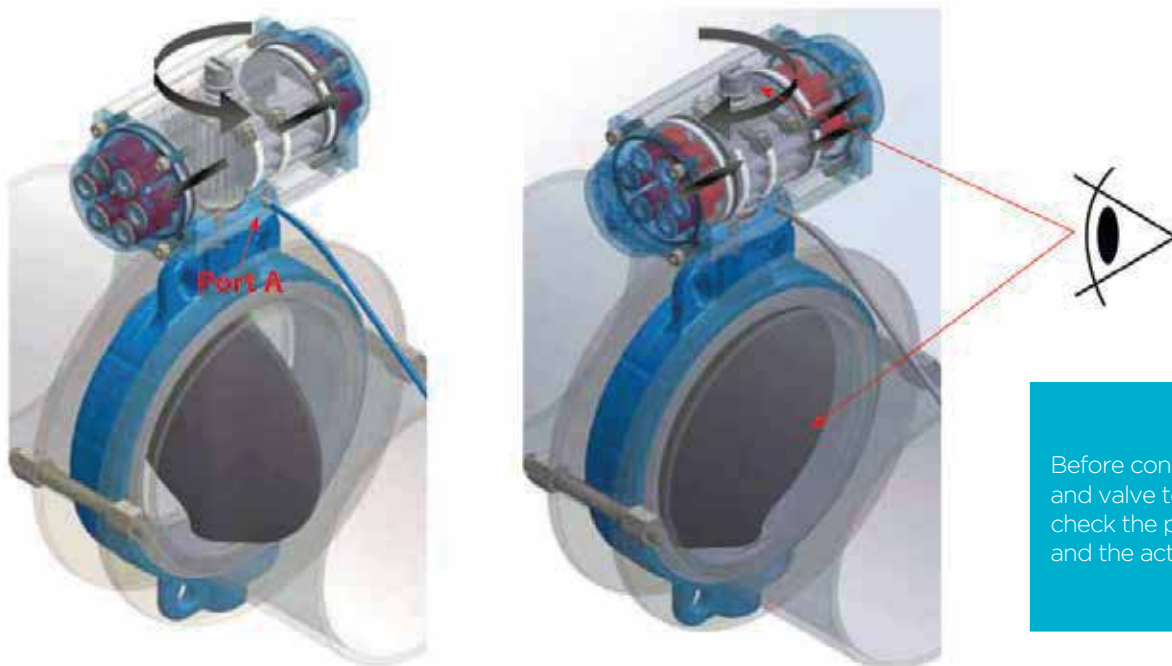

Before connect the actuator and valve to the piping system, check the position of the valve and the actuator pinion

Port A: Pressurized to open the valve. Actuator rotates CCW for opening.
 Port A: Non-Pressurized and springs made their jobs for closing the valve. Actuator rotates CW for closing.

c. Operation of 3 Position Actuator

In order to operate the 3 position actuator, can be benefited from the 3/2 solenoid valve. (Figure 10)

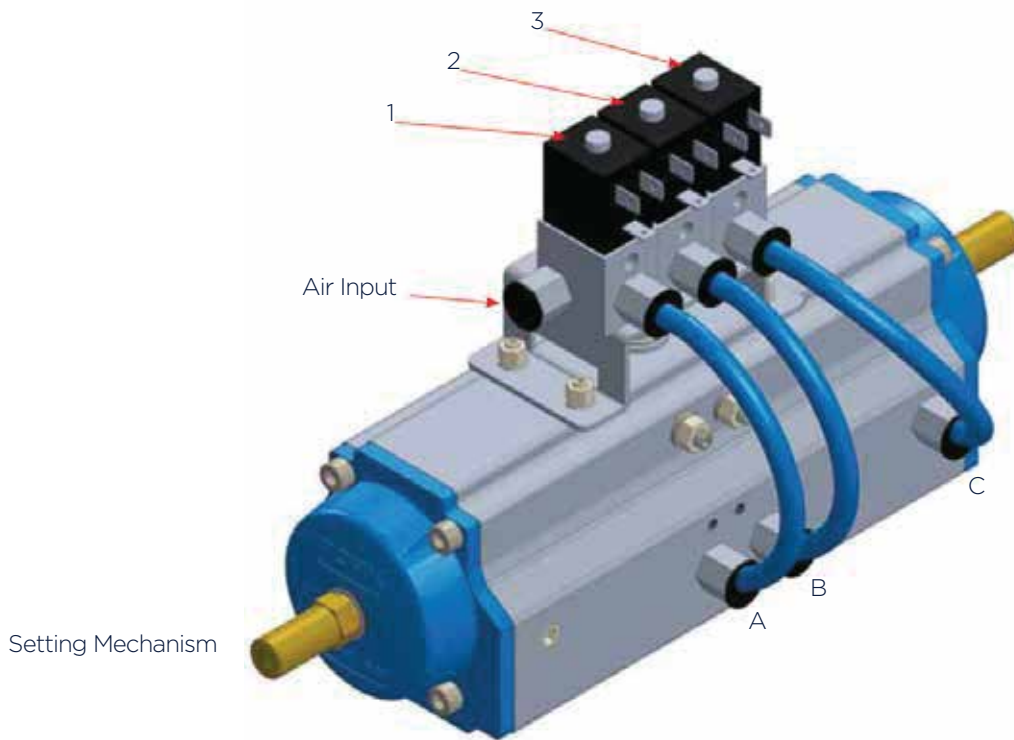

Fig 10. 3 position actuator

a) Mounting: Fortriple 3/2 solenoid valve; the valve with number 1 should be connected to A port, the valve with number 2 to B port and the valve with number 3 to C port.

b) Operating:

- 1) Pressure air is given to air input port.
- 2) The coil with number 1 is powered. In this way, the actuator turns 90° and switches to fully open position.
- 3) The coil with number 3 is powered and the power of coil with number 1 is shut off. In this way actuator is half closed. Half closed position can be regulated between 30-60°.
- 4) The coil with number 2 is powered and the power of coil with number 3 is shut off. In this way actuator is fully closed.

3. INSTALLATION OF THE EQUIPMENT

a. Mounting the Actuator to Valve Assembly

Inline position

- I. Adjust the valve to closed position by using a wrench.
- II. Do not use hammer for adjusting the valve shaft.

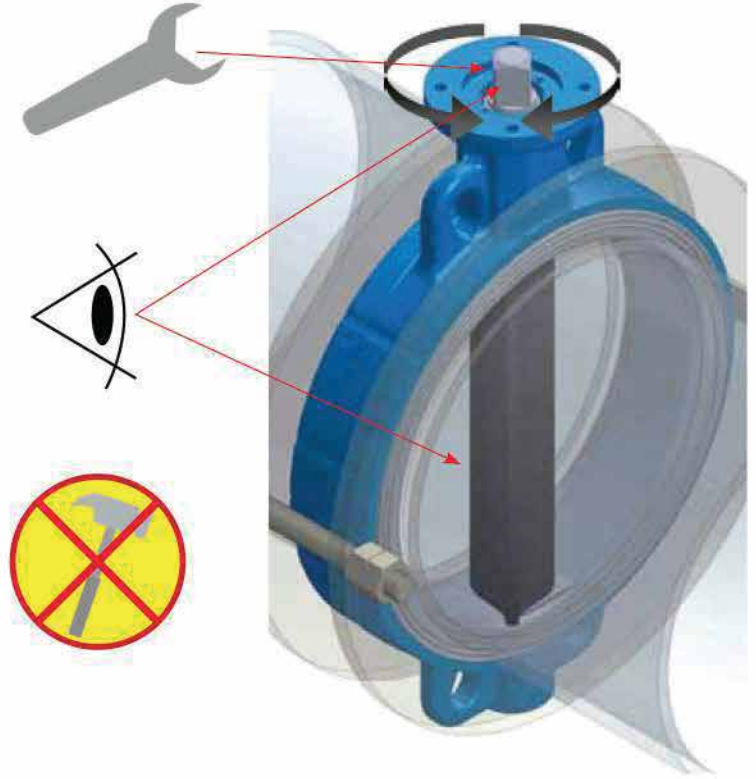

- III. Mount the bracket on valve by using screws and nuts like in the picture. Place the extension on valve pinion directly.

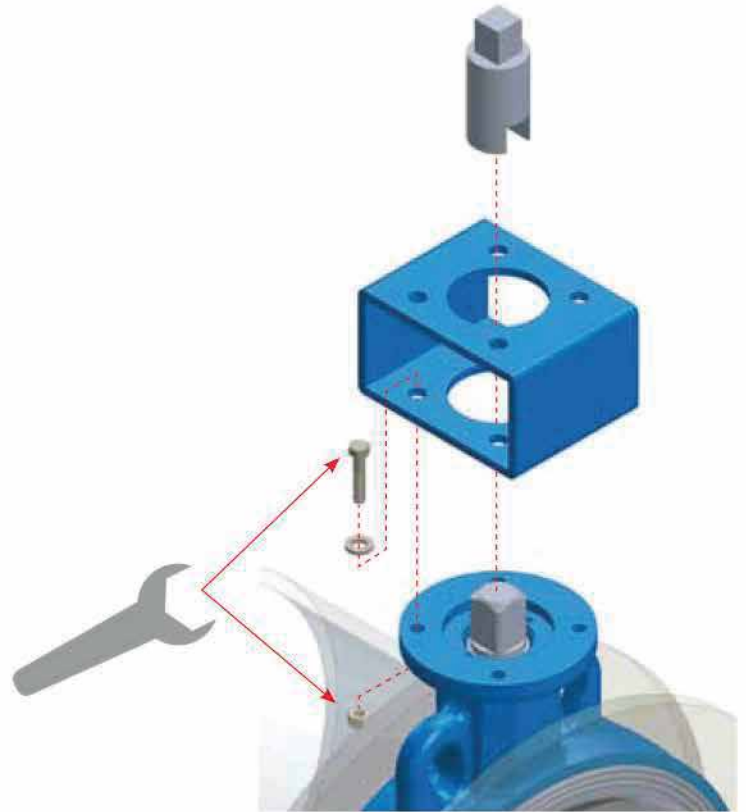

IV. When mounting the actuator pay attention to open and close position of valve.

Before connect the actuator and valve to the piping system, check the position of the valve and the actuator pinion

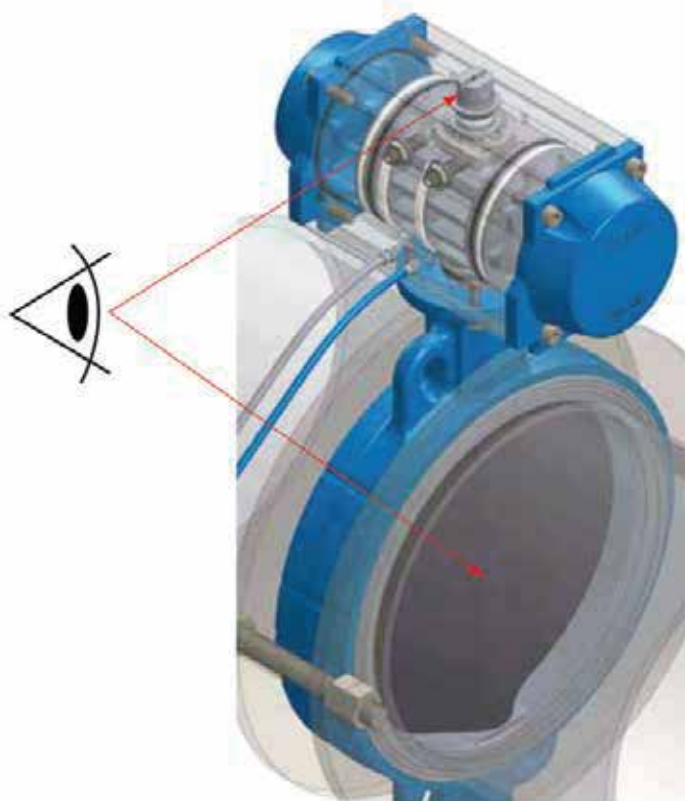

V. Mount the actuator to the valve with set screw and nut by suitable tools.

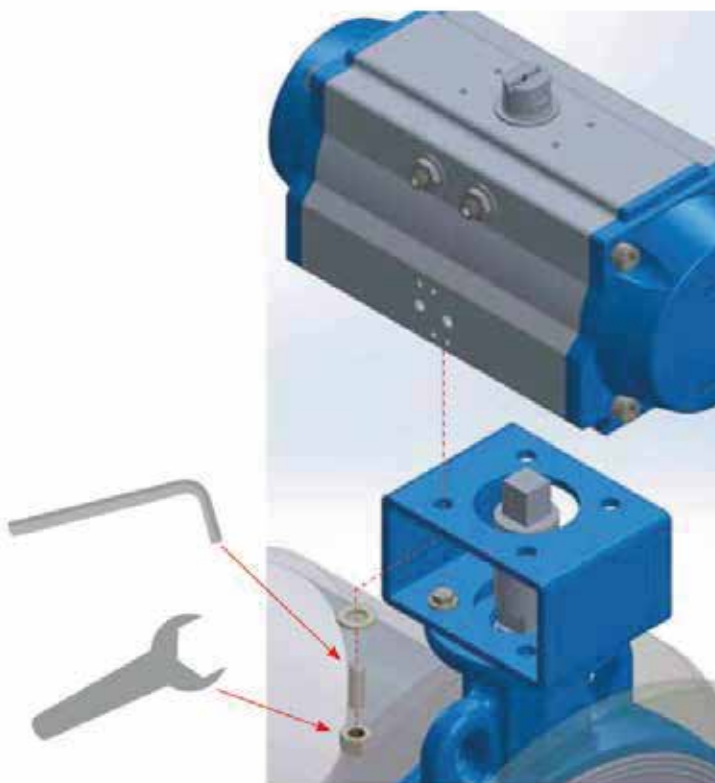

VI. Mount the actuator to the valve with screw by suitable tools.

b. Stroke Adjustment

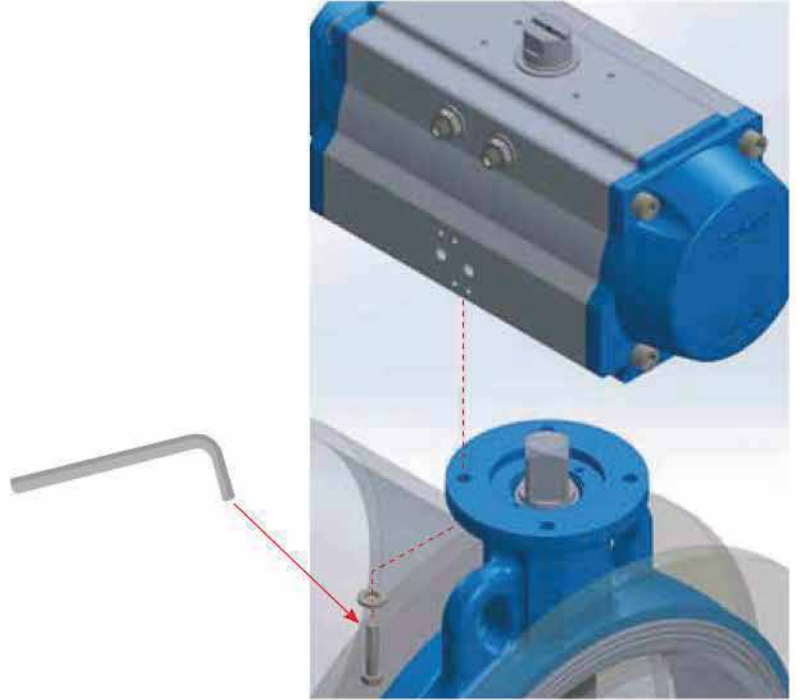
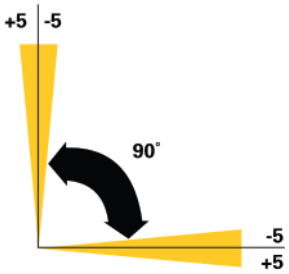

Double Acting Actuators (Open Position)

I. Connect the actuator to pressurized air system. Give some pressure to "Port A" to open the actuator.

II. Adjust the pistons to accurate position by using wrench.

III. Turn the left set screw until an obstruction is felt. Do not turn anymore and do not force it. For lock the set screw use lock nut.

Double Acting Actuators (Close Position)

I. Connect the actuator to pressurized air system. Give some pressure to "Port B" to close the actuator.

II. Adjust the pistons to accurate position by using wrench.

III. Turn the right set screw until an obstruction is felt. Do not turn anymore and do not force it. For lock the set screw use lock nut.

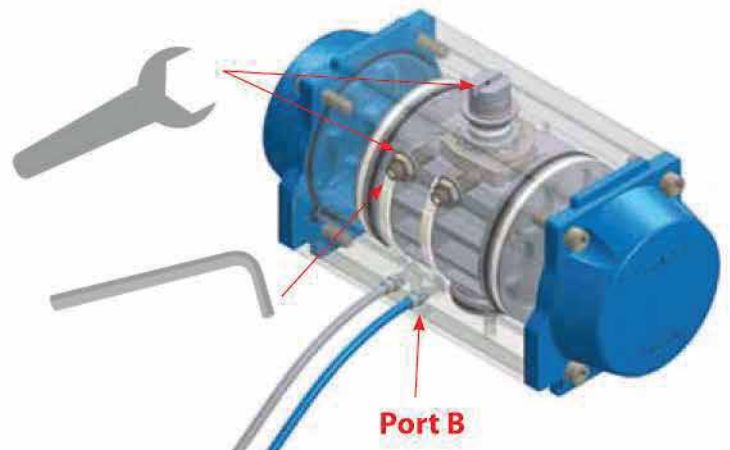
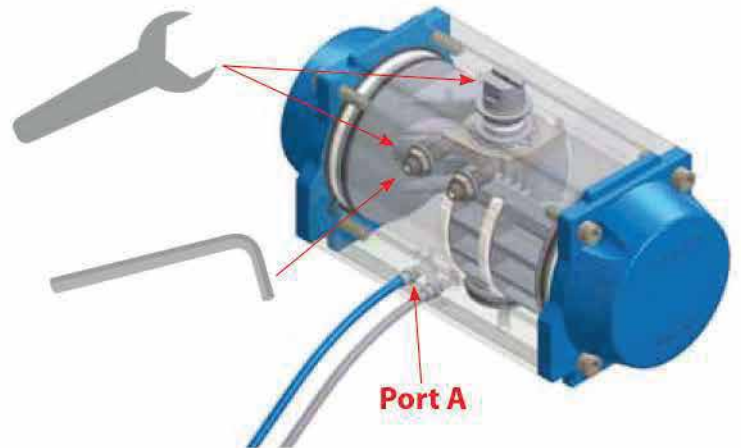

Spring Return Actuators (Open Position)

- I. Connect the actuator to pressurized air system. Give some pressure to "Port A" to open the actuator.
- II. Adjust the pistons to accurate position by using wrench.
- III. Turn the left set screw until an obstruction is felt. Do not turn anymore and do not force it. For lock the set screw use lock nut.

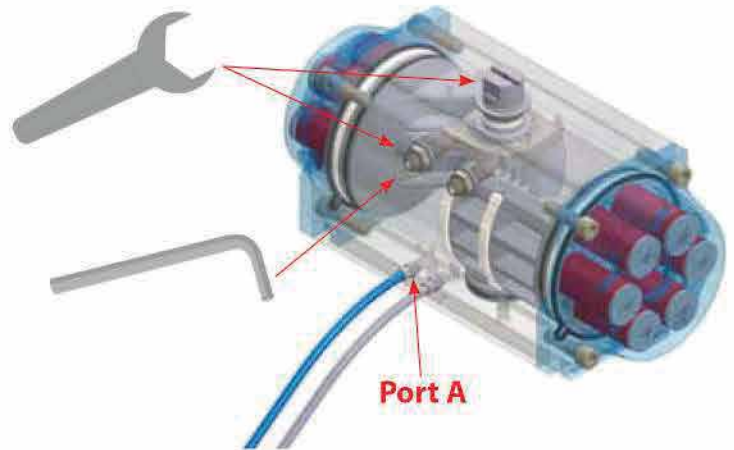

Spring Return Actuators (Close Position)

- I. Release the pressure in "Port A". Springs would close the actuator.
- II. Adjust the pistons to accurate position by using wrench.
- III. Turn the right set screw until an obstruction is felt. Do not turn anymore and do not force it. For lock the set screw use lock nut.

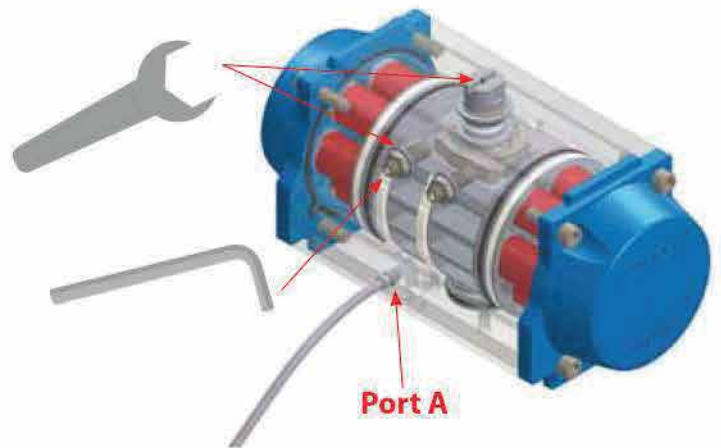

c. Mounting the Namur Solenoid to Actuator Assembly

- I. Mount the solenoid to the actuator with socket head screw by suitable tools.

Note: To prevent the "water hammer" connect the throttle valve(s) to the namur solenoid exhaust(s) with suitable tool and sealing. "Pressurized air discharge time can be adjusted with throttle valve (s) thus the valves Opening or Closing speed adjusted too." For this optional throttle valve, you should inform us when ordering the pneumatic actuator.

❗ Pneumatic connections should be disconnected before any intervention.

❗ For protection against potentially explosive atmospheres use certified ex proof Namur solenoid valves and "RX" code ex proof pneumatic actuators.

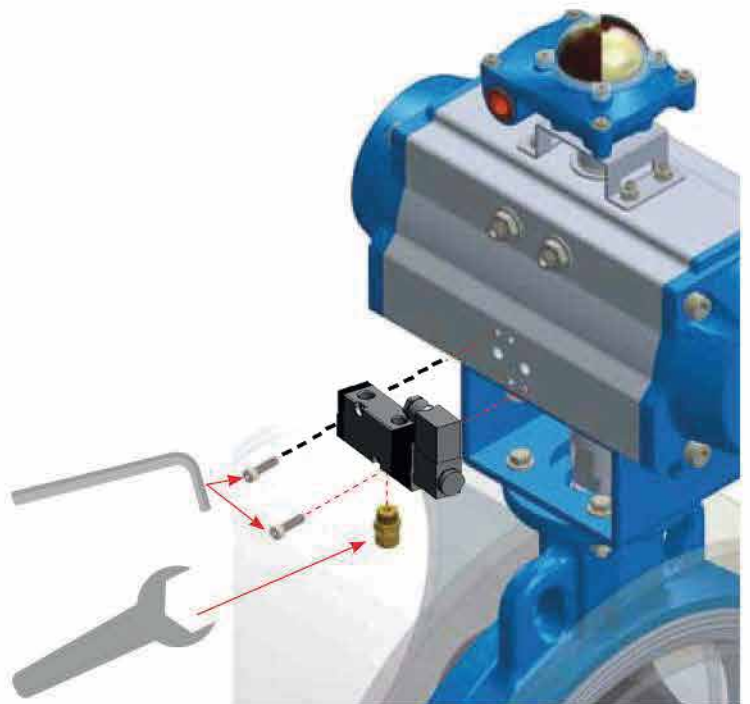

d. Mounting the Switch Box to Actuator Assembly

I. Mount the switch box to the actuator with set screw and nut by suitable tools.

Before connect the actuator and switch box, check the position of the switch box and the actuator pinion

! Pneumatic connections should be disconnected before any intervention.

! For protection against potentially explosive atmospheres use certified ex proof switch box and "RX" code exproof pneumatic actuators

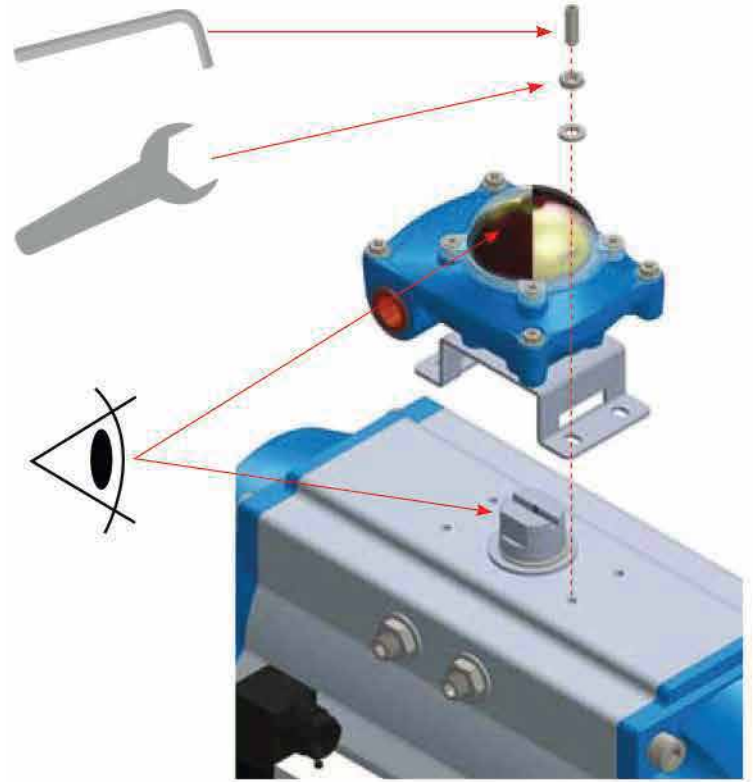

e. Mounting the Position Indicator to Actuator Assembly

I. Mount the position indicator to the actuator with flat screw by suitable tool.

Before connect the actuator and switch box, check the position of the switch box and the actuator pinion

! Pneumatic connections should be disconnected before any intervention.

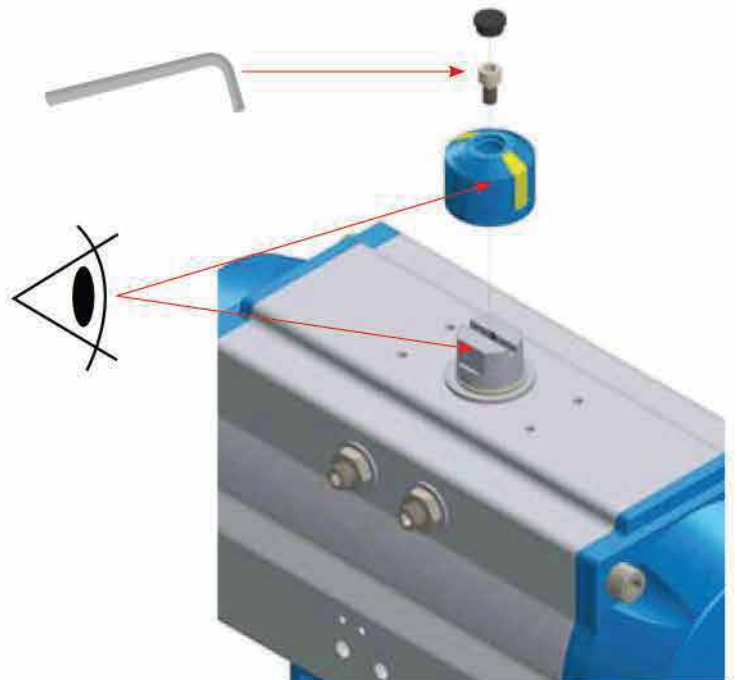

f. Ground Connection

In exproof models mount the main supply ground cable socket (color code is yellow green) to the ground connector on the pneumatic actuator.

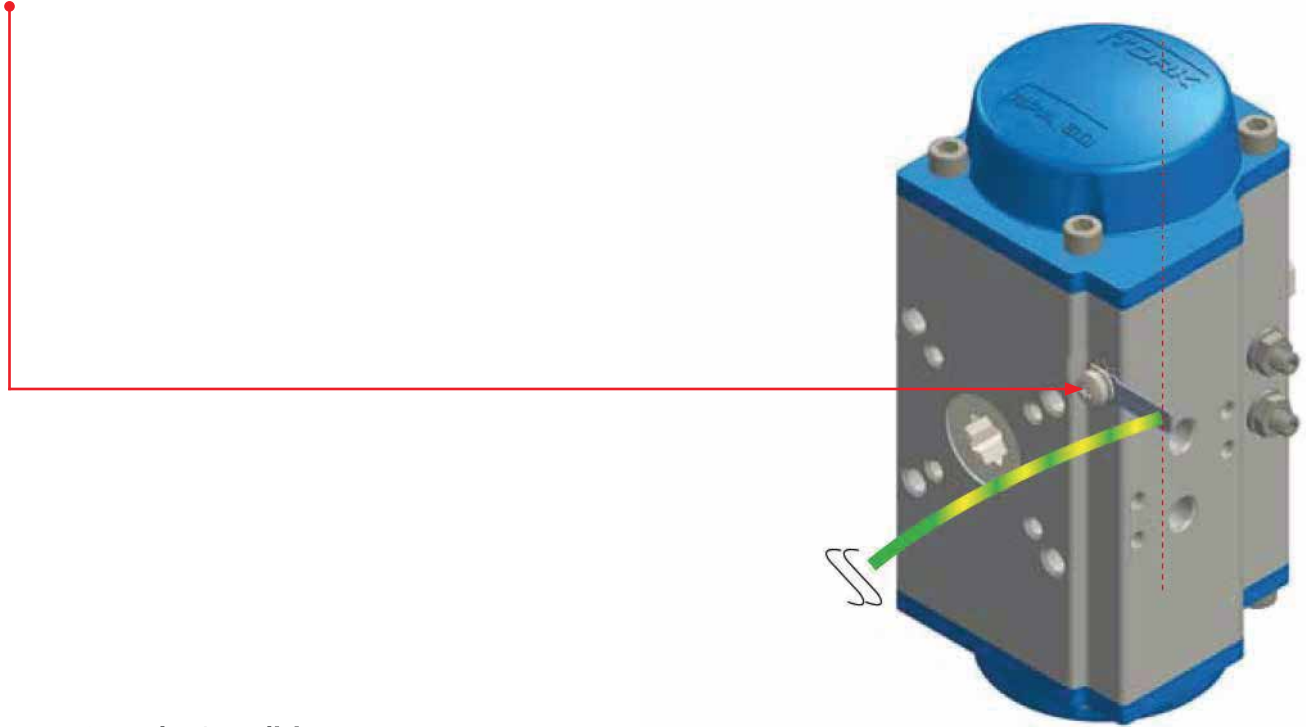

g. Actuator Supply Condition

! Before connect the air system to actuator, use air filter, pressure, and oiler. For the accurate operation temperature and pressure ranges are listed below. Responsibility for supply condition belonged to the user. For any damage on or in the pneumatic actuator cause of different supply condition listed below, company has no responsibility. Service actions would be taken with a fee.

PRESSURE (bar)	
Double Acting	2,5 bar ... 8 bar
Single Acting	4 bar ... 8 bar
TEMPERATURE (°C)	
Standard	-20 °C ... 80 °C
On Request	-20 °C ... 150 °C or - 60 °C ... 80 °C

Recommended piping for the inlet and outlet pneumatic connections to the actuator of the device is PVC tubing. The length of tubing between the device and the actuator shall be kept as short as possible and if possible free of kinks.

Only dry air filtered to 50 micron or better is recommended. The process air pressure shall meet the requirements. The process air capacity shall be sufficient to move the valve actuator within the required time.

4. SAFETY MANUAL

This section provides necessary information for meeting the IEC 61508 functional safety standards and to design, install, verify and maintain a Safety Instrumented Function (SIF).

4.1 Responsibilities for Safety

The safety of design and operation of a safety-related system, in which the device is implemented, must be ensured by manufacturer and operator.

4.1.1 Responsibility of Manufacturer

- Safe design of the device
- Providing of all safety-related information to the operator of the overall system
- Compliance to all regulations and guidelines that allow a safe commissioning

4.1.2 Responsibility of Operator

- Instructing of personnel working on the overall system
- Maintaining the safe operation of the overall system
- Compliance to all regulations and guidelines regarding occupational safety
- Ensuring of periodic test of the overall system by qualified employees

4.2 Terms and Abbreviations

FMEDA	Failure Modes, Effects and Diagnostic Analysis
HFT	Hardware Fault Tolerance
PFD _{AVG}	Average Probability of Failure on Demand
SFF	Safe Failure Fraction
SIL	Safety Integrity Level Discrete level (one out of a possible four) for specifying the safety integrity requirements of the safety functions to be allocated to the E/E/PE safety-related systems where Safety Integrity Level 4 has the highest level of safety integrity and Safety Integrity Level 1 has the lowest.
SIF	Safety Instrumented Function A set of equipment intended to reduce the risk due to a specific hazard (a safety loop), Safety instrumented control/protection function
SIS	Safety Instrumented System Implementation system of one or more Safety Instrumented Functions. A SIS is composed of any combination of sensor(s), logic solver(s), and final element(s).
DC	Diagnostic Coverage Factor (if diagnostic measures exist)
PTC	Proof Test Coverage Factor Names how many dangerous undetected failures can be detected during Proof Test
PFH	Average Frequency of a dangerous failure per hour
MTBF _(D)	Mean Time between (dangerous) Failures

Tab 14. Terms and Abbreviations

4.3 Related Standards

Functional safety as IEC 61508 Parts 1,2,4,7:2010 CMV Commented version.

5. FUNCTIONAL SAFETY RELEVANT SPECIFICATIONS

5.1 Application and Environmental Limits

The tested device is intended for media such as Gas and Fluid. The applicable fluid shall be clean and non-corrosive fluid. Required Air-quality-level in accordance to ISO 8573-1: 7-1-4 for particles – water – oil. The tested device is rated up to 4 bars and up to 8 bars. For the detailed materials of construction of tested device, please refer to user manual, operation instruction, maintenance instruction.

The pneumatic actuator is intended for use in Indoor, Outdoor and/or Hazardous Area (ATEX II 2GD c T4) at temperature range of -20 °C to 80 °C.

5.2 SIL Capability

The actuators are suitable for use in a safety instrumented system up to SIL 2 (low demand mode). Under consideration of the minimum required hardware fault tolerance HFT = 1 the actuators may be used in a redundant architecture up to SIL 3. The development and manufacturing process and the functional safety management applied by the manufacturer in the relevant lifecycle phases of the product has been inspected and assessed as suitable for the use in applications with a maximum Safety Integrity Level of 3 (SC 3).

Route of Assessment		2H / 1S	
Type of Sub-system		Type A	
Mode of Operation		Low Demand Mode	
Hardware Fault Tolerance	HFT	0	
Lambda Dangerous confidence level of calculation $1-\alpha = 95\%$	λ_D	3.50 E-07/h	350 FIT
Lambda Dangerous Undetected assumed Diagnostic Coverage DC = 0 %	λ_{DU}	3.50 E-07/h	350 FIT
Mean Time To Dangerous Failure	MTTFD	2.86 E+06 h	326 a
Average Probability of Failure on Demand 1oo1 assumed Proof Test Interval T1 = 1 year	$PFD_{avg}(T_1)$	1.53 E-03	
Average Probability of Failure on Demand 1oo2 assumed Proof Test Interval T1 = 1 year assumed $\beta_{1oo2} = 10\%$	$PFD_{avg}(T_1)$	1.53 E-04	

Tab 15. Device specific parameters

5.3 Requirements Of Other Components

In order to determine whether tested device is suitable for use in a certain safety-related system, it is necessary to determine the PFDavg value of the overall system. Usually it is presumed that a final element (valve + actuator) uses up to 50 % of the total available PFDavg value.

6. OPERATION AND MAINTENANCE

- It is recommended that pneumatic actuators are operated every 3 months in case of long-term storage and inactivity. This will prevent the flexibility of the sealing equipment and prevent permanent deformations.
- The amount of oil in the body should be checked once a year in working products and piston and moving surfaces must be lubricated with grease.
- All air inlets and outlets should be closed for prevent pollutants or abrasive substances from entering not only in the actuator but also in all equipment such as directional control valves or locators. All openings, such as the power line to the junction boxes, must also be closed.
- Use appropriate silencers on actuator or directional valves.
- Actuators should not be stored in an atmosphere which is harmful to the sealing material. If it is, closed warehouse must be preferred.
- It is recommended to replace piston and shaft sealing and lining elements once every 2 years in working products.
- The air quality to be used for the actuator must be comply with ISO 8573-1: 7-4-4 (Particle - Water - Oil) standards.

6.1 Proof Test Interval

The objective of proof testing is to detect failures within the device that are not detected by any automatic diagnostics of the system. Of main concern are undetected failures that prevent the SIF from performing its intended safety function. The proof tests must be performed at every year. The suggested proof test consists of the steps as described in the table 3.

Step	Action
1	Bypass the safety function and take appropriate action to avoid a false trip
2	The actuator is brought to the half-open position.
3	Closing time and pressure values from both channels are measured
4	Pressure values from both channels are measured again after nearly 10 seconds have elapsed.
5	Determined if there is any air leakage. Air leakage shows to determine if the actuator is damaged or the seals are broken.
6	The actuator is brought to the full-open position. The opening time is measured
7	The opening and closing times show to determine if the actuator is jammed or normal.
8	Inspect the appliance and other last components for any leakage, visible damage or contamination.
9	Record the test results and any failures in your company's SIF inspection database
10	Remove the bypass and restore normal operation

Tablo 16. Proof test

Proof test coverage factor (PTC) = 95 %

6.2 Maintenance

After five years a complete maintenance and overhauling should be performed. Within this procedure aged and worn components should be changed. The device must be maintained in accordance to Installation, Operation and Maintenance manual. Due to the intensive proof the Maintenance Coverage Factor can be set to: MTC = 100 %

6.3 Repair and Replacement

Repair procedures in the device Installation, Operation and Maintenance manual must be followed. The SIL rating of the device may be voided if the repair is not performed with OEM parts and serviced by unqualified personnel.

6.4 Useful Lifetime

A time of usage of more than 5 years (+ 1.5 years of storage) can only be favored under responsibility of the operator, consideration of specific external conditions, and adequate test cycles. If it is periodical maintenance and appropriate use, the useful life is ten years. But the non-ageing-resistant parts must be replaced during periodical shutdown maintenance.

6.5 Manufacturer Notification

All faults must be reported to manufacturer for recording purposes, by contacting the Quality Department at address below. All defective devices must be returned to manufacturer for investigation and rectification. A device Return and Service Report form (available upon request, from the address below) must be completed and returned with the device.

WARRANTY CONDITIONS

1. If there is a fault caused by the production, the manufacturer will repair or replace the defective product in its sole discretion.
2. The warranty period is two (2) years and starts from the date of delivery of the product to consumers.
3. All products, including all sub-parts, covered by our warranty.
4. The maximum repair time is one (1) month and starts from the products' arrival date to SMS factory.
5. Within the warranty period, both in material and workmanship, as well as in case of manufacturing defects, products will be repaired without any charge under any name (labor costs, or the cost of replaced parts).
6. During the warranty period, provided that the products will be exchanged free of charge if the fault is sourced by production.
7. Damages caused by the using of the product contrary to the points listed in the operating instructions are excluded from warranty coverage.
8. If there are complaints about the product please contact customer relations manager firstly.
9. For return or repair-maintenance of products send them to the factory to the customer relations department.
10. If products come to the factory, it doesn't mean acceptance of return and received by officers. Returns accepted, with the approval of the examination will be only after the relevant department managers.
11. Consult to General Directorate of Consumer and Competition Protection of the Ministry Industry and Commerce of Turkey about the issues may arise with warranty certificate.

EXCLUSIONS OF WARRANTY (USAGE DEFECTS)

1. Malfunctions occurring after the expiration of the statutory warranty,
2. The faults caused by improper use of the product by the user, (improper using to the instruction manual),
3. Any relevant malfunctions caused by other equipment in use,
4. Changes and damages not caused by the product manufacturer; for example, the case of the opening of the product by not authorized workshops,
5. All failures depend on the system (electricity, air, etc),
6. Failures depend on the intervention of unauthorized service,
7. Products with damaged or destroyed warranty label,
8. In case of damage to outer surface of the product,
9. The faults in the caused by falling, hit, etc,
10. Faults occurred on dusty, damp, extreme heat or cold environments,
11. Faults caused by natural disasters such as flood, fire, earthquake, lightning, etc,
12. Faults caused by electrostatic discharge (ESD) damage.



WARRANTY CERTIFICATE

Manufacturer : SMS Sanayi Malzemeleri Üretim ve Satışı A.Ş.

Address : Head Office: Y.Dudullu Mh. Bostancı Yolu Kuru Sk.
No: 16 Ümraniye - İstanbul / TURKEY

Factory: İMES O.S.B 5. Cd. No: 6 Çerkeşli OSB Mh.
Dilovası - Kocaeli / TURKEY

Product : PNEUMATIC ACTUATORS

Trade Mark : TORK

Model :

Serial Number :

Delivery Place & Date :

Warranty Period : 2 Years

Max. Repair Time : 20 working days

Seller / Distributor :

Address :

Manufacturer Representative

Name / Surname :

Title :

Date :

Signature :

Seller / Distributor Representative

Name / Surname :

Title :

Date :

Signature :



PIONEER OF THE INDUSTRY SINCE 85

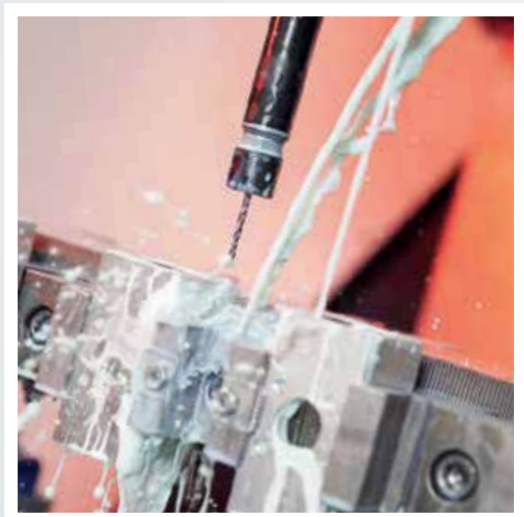

tork

valve & automation

HEAD OFFICE Bostancı Yolu Cad, Kuru Sok, No:16 Y. Dudullu, 34776 Ümraniye İstanbul -TÜRKİYE

FACTORY İMES O.S.B. Cad. No:5 Çerkeşli - Dilovası KOCAELİ - TÜRKİYE

SMS-TORK Endüstriyel Otomasyon Ürünleri San. Tic. Ltd. Şti.

P +90 216 364 34 05 P +90 216 364 37 57

P +90 262 290 20 20 P +90 262 290 20 21

📞/SMSTORK @/sms-tork www.smstork.com